

Dimming Actuator, 4-fold

User Manual

KTE45BD

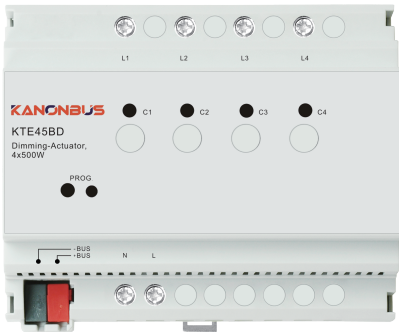

1

Safety instructions

- Before installation, please read user manual carefully and observe relevant standards, directives, regulations and instructions.
- Electrical equipment must be installed and programmed by qualified technicians only.
- This device is manufactured according to the relevant technical specifications and have CE.
- For more information of this product, please contact the technical engineer of manufacturer.
- Users are not permitted to alter and maintain the product without the authorization of manufacturer.
- Failure to observe the instructions may cause damage to the device and result in fire or other hazards.

Product Overview

KTE45BD dimming driver uses the KNX protocol to turn on/off lights and adjust brightness and darkness. It adopts cutting-edge bidirectional thyristor dimming and has 4 independent dimming channels, each supporting a maximum load of 500W. The load types include dimming, stepless speed regulation, etc., which can be applied to incandescent lamps, low-voltage halogen lamps, and lamps/LED lamps with electronic adapters with thyristor input. Each channel can be individually set with control switches, relative dimming, and absolute dimming, and can read feedback on switch status and absolute dimming values, while also having scene functionality. You can also set the dimming speed, turn on brightness, etc. KTE45BD dimming driver is connected using a bus terminal and powered by a KNX power supply, and can operate without the need for an auxiliary power supply. All input ports of the driver share one input power supply, and each port can output a maximum load current of 2.5A.

2

Product Features

- Implement the on/off/dimming action of the load output of the dimming driver through the KNX protocol
- 4 independent dimming channels, each capable of carrying a load of 50W~5000W
- Each circuit has an independent status display
- Each circuit can be individually set with relevant parameters
- Manually control the on/off/dimming of each circuit
- Supports relative dimming commands (4 bits)
- Supports absolute dimming command (1-byte)
- Scene function
- The dimming speed can be set
- The gradient speed of the switch can be set
- Can set the brightness to be turned on
- Use ETS for programming and debugging

Programming instructions

1. Select the corresponding product database and import it into ETS;
2. Add the device to the project created by ETS;
3. Press the device programming button to download the physical address through ETS. After the download is complete, the red LED indicator light will turn off;
4. Open the device database, set its parameters and associate them with the corresponding group objects, and then download the application;
5. After changing the physical address of the device, repeat step 3;
6. After modifying parameter settings or re associating group objects, repeat step 4 to achieve the new functionality.

3

Product parameters

Parameters	Types	KTE45BD
Power		
Power Supply		KNX Power, 21V~30V DC
Transmission Media		KNX TP
Power Consumption		≤10 mA
Load output		
The number of output channels		4
Maximum load of a single circuit		500W
Minimum load of a single circuit		50W
Total load		500W×4
Rated voltage		230V AV
Rated current		
Output wiring		0.5mm ² ~4mm ²
Manual control mode		electronic type

4

Product Wiring

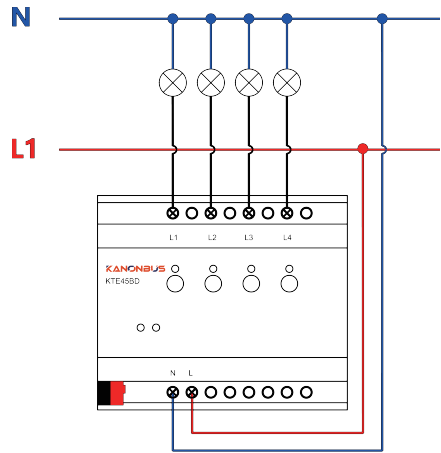

5

Product dimensions

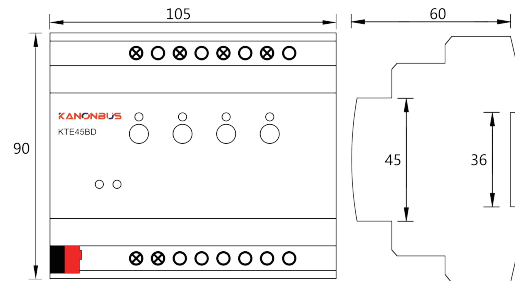

6

Operating instructions

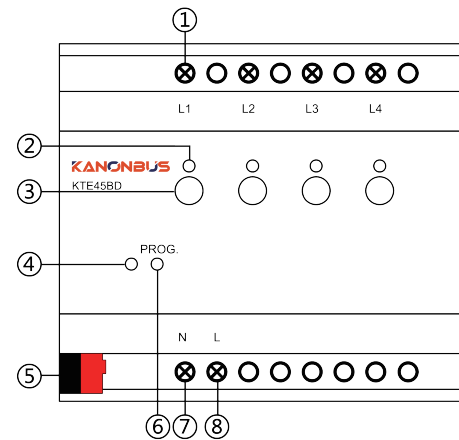

7

Operating instructions

- ① Load output terminal
- ② Load LED status indicator light, always red when the load is turned on
- ③ Load output manual button, short press to turn on/off the corresponding load, long press to adjust the brightness of the corresponding load
- ④ KNX programming button indicator light, when the programming button is pressed, the indicator light displays in red. After downloading the physical address, it automatically turns off, or it can be powered on/off through ETS software
- ⑤ KNX bus terminal, used to connect KNX system
- ⑥ Programming button, press it to write the physical address of the device
- ⑦ Power supply neutral terminal
- ⑧ Power supply live wire terminal

8